

Powerful Solutions for Welding and Cutting Automation with Precision and Versatility!

The Modular Drive System is a powerful machine that allows the operator to custom configure one machine for various applications and runs on standard BUG-O SYSTEMS Rail.

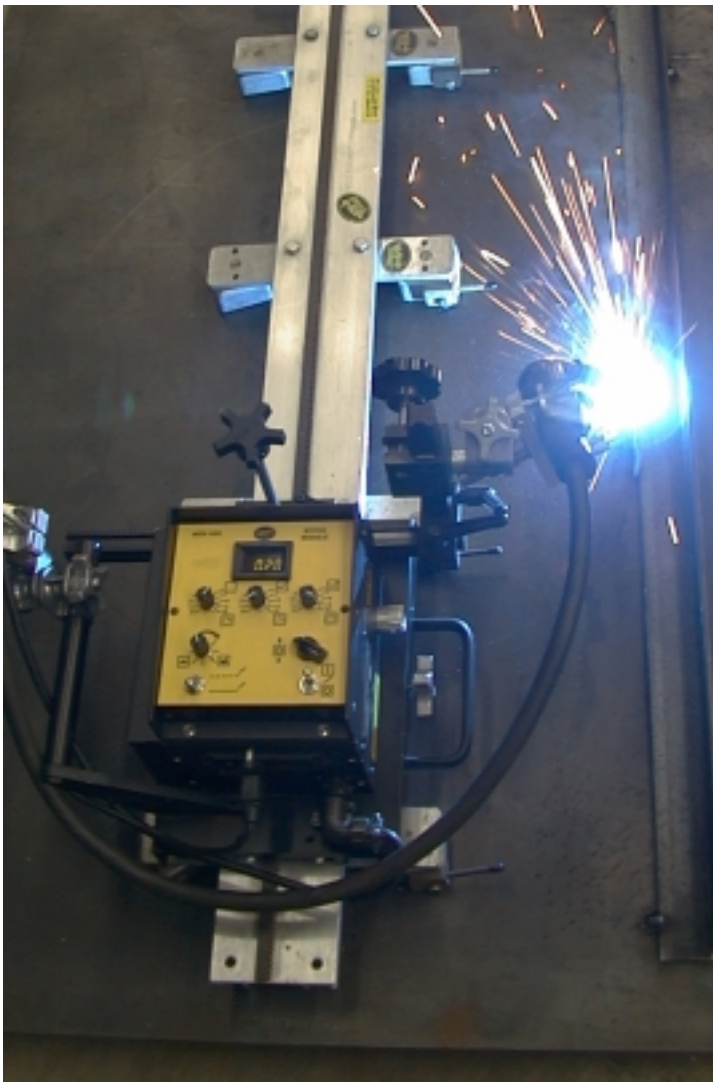

The modular design allows the user to quickly reconfigure the unit for straight line cutting or welding, stitch welding or weave welding, all with the same machine!



BUG-O SYSTEMS

A DIVISION OF WELD TOOLING CORPORATION



3001 WEST CARSON STREET PITTSBURGH, PENNSYLVANIA USA 15204-1899
PHONE: 1-800-245-3186 <http://www.bugo.com> TELEFAX: 1-412-331-0383

The Modular Drive System is the only product in the industry that allows the user to configure one machine for various automated applications, now and in the future!

Future development has been engineered into the system allowing its modular components to be easily upgraded. As tomorrow's technologies are introduced, the Modular Drive System can be enhanced to take advantage of new features and capabilities as they are perfected. Other systems will be obsolete as the Modular Drive System will remain "state of the arc" in portable motion control!

The Modular Drive System produces precise, accurate cuts and welds.

The Master Drive Unit has a high torque, low inertia motor for precise stops and starts and a dedicated fail-safe brake with three times the stopping and holding power of the motor. The unit is equipped with motor overload protection which turns the motor off and engages the brake whenever an excessive load is placed on the machine. In addition, the Master Drive features closed loop speed control for adjustable, repeatable control of critical welding or cutting parameters, and closed loop position control to prevent creep.



Assembling a Modular Drive System is easy!

Straightline cutting and welding configurations consist of a Control Module, Master Drive Unit, Machined Racking Group, and Carriage. An optional Remote Control Cable (see page 6) can be used to remote the Control Module, and a Universal Limit Kit to add cycler, stop at limit, and rapid return functions.

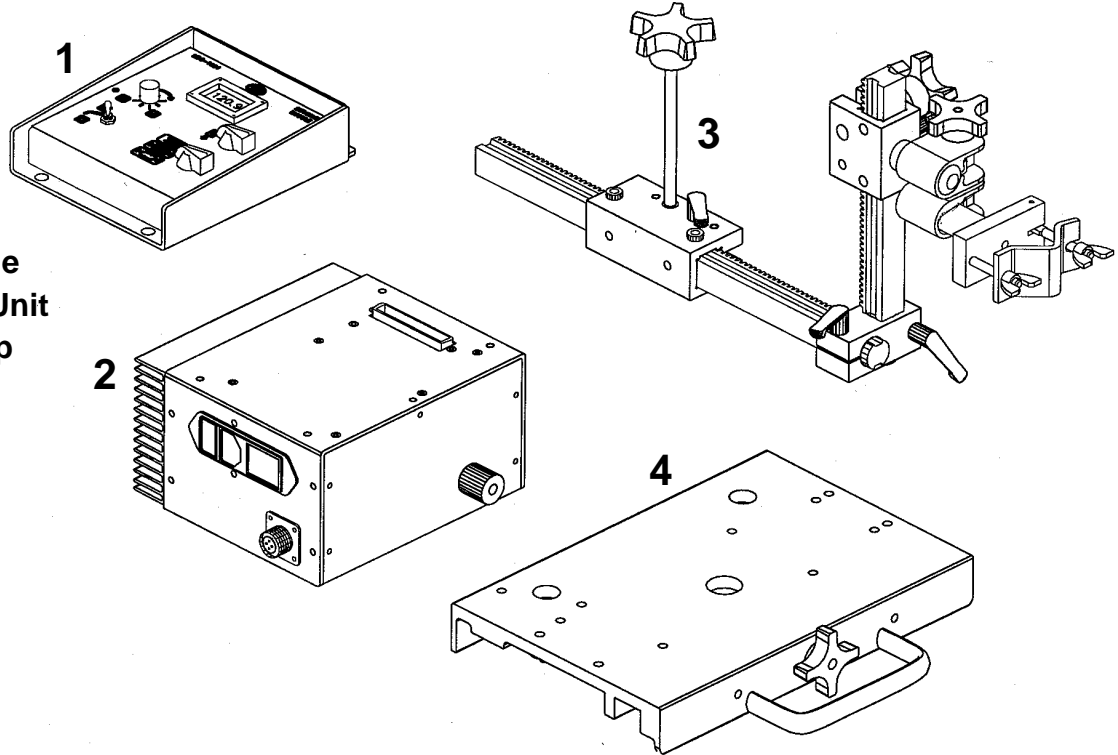

1. Control Module
2. Master Drive Unit
3. Racking Group
4. Carriage

Control Modules

A Control Module plugs onto the top of the Master Drive Unit and operates various machine functions. Three Control Modules are available; one for straightline cutting and/or welding, one for stitch welding; and one for weave welding capability.

Control Modules

Order reference: **MDS-1001** Straightline Module
MDS-1003 Stitch Welding Module
MDS-1005 Weld Weaving Module



MDS-1003 Stitch Module

Master Drive Unit

At the heart of the Modular Drive System is the Master Drive Unit which houses the motor, speed control board, power supply, and clutch, that allows rapid manual positioning of the carriage anywhere along the track. The unit runs from 2-120 in/min (51-3048 mm/min) with a vertical load capacity of 60 lbs (27 kg) and a horizontal load capacity of 100 lbs (45 kg).

Master Drive Unit

Order reference: **MPD-1000** 120VAC/50-60 Hz
MPD-1002 240VAC/50-60 Hz
MPD-1004 42VAC/50-60 Hz



MPD-1000 Master Drive Unit

Racking Groups

There are two machined rack torch mounting groups in the Modular Drive System, one for plasma or oxy-fuel cutting and the other for welding.

Machined Rack Cutting Group

Order reference: **MDS-1050**



Machined Rack Welding Group

Order reference: **MDS-1040**

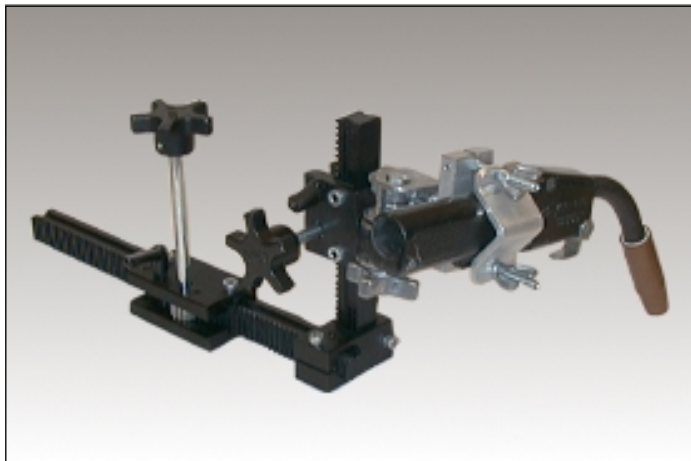

Carriages

Two carriages are available for the Modular Drive System when using BUG-O Aluminum Rigid and Semi-Flex Rails.* One is a releasable 12" carriage equipped with an engagement knob that allows the unit to be placed anywhere along the track. The other is an 18" carriage shown on page 5.

Order reference: **MPD-1065** Releasable Carriage 12"



MPD-1065 Releasable Carriage 12" on Aluminum Rigid Rail.

Hi-Flex carriages are designed for use with the Modular Drive System when running the equipment on BUG-O Hi-Flex Stainless Steel Rail.* Each carriage has a built-in quick release for mounting or removal at any point along the rail. A cable anchor is also included to keep welding cables and contact wires away from the work surface.

Order reference: **FMD-1100** Drive Carriage

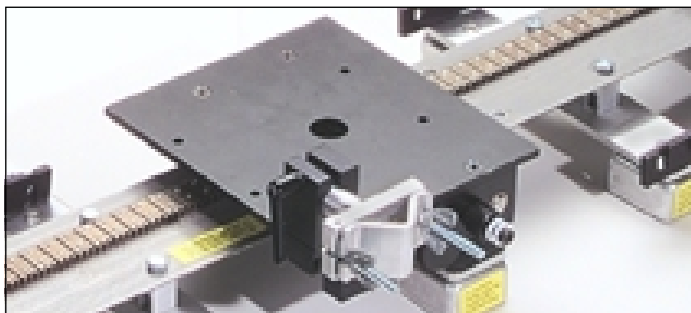

FMD-1100 Flex Rail Carriage w/Cable Anchor on Hi-Flex Rail.

For applications using the Modular Drive System on BUG-O Bent Aluminum Rigid Rail,* a split carriage is available. This releasable carriage can be placed anywhere along the track and easily adjusts to various work diameters. (For outside radii only)

Order reference: **BUG-5910** Tube Carriage



BUG-5910 Tube Carriage on Bent Aluminum Rigid Rail.

* Note: see Rails and Attachments brochure for information on BUG-O Systems rails.

Modular Drive System Accessories

Carriage Trailer w/Hitch for Aluminum Rigid and Semi-Flex Rails supports various accessories. (Non-releasable)



Order reference: **BUG-2205**

18" Carriage has extended deck for mounting accessories, wire feeders, etc. (Non-releasable)

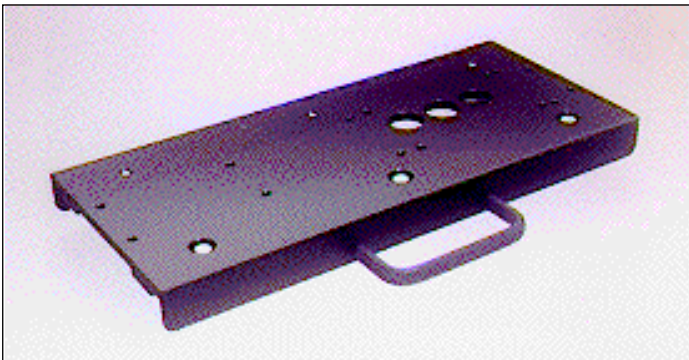

Order reference: **MPD-1055**

Short Trailer for Hi-Flex Rail carries Modular Drive Weavers. (Releasable)

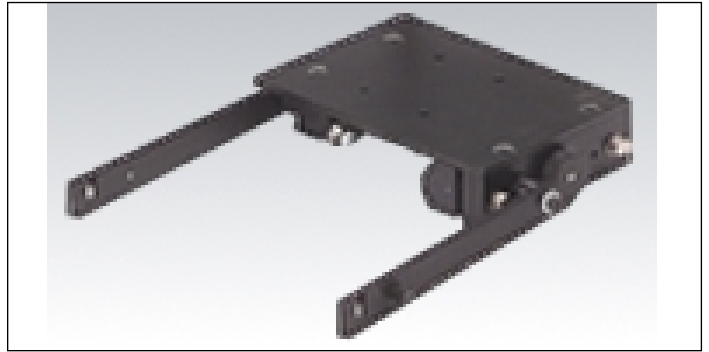

Order reference: **FMD-1095**

Long Trailer for Hi-Flex Rail supports various accessories. (Releasable)



Order reference: **FMD-1090**



Universal Limit Kit

Installs between the Master Drive Unit and any of the control modules. This limit kit adds the ability to cycle between limits, stop at limit, or rapid return. All existing functions of the control modules are maintained.

Order reference: **MDS-1055** For Rigid Rail Applications
FMD-1045 For Hi-Flex Rail Applications (not shown)

Modular Drive System Accessories

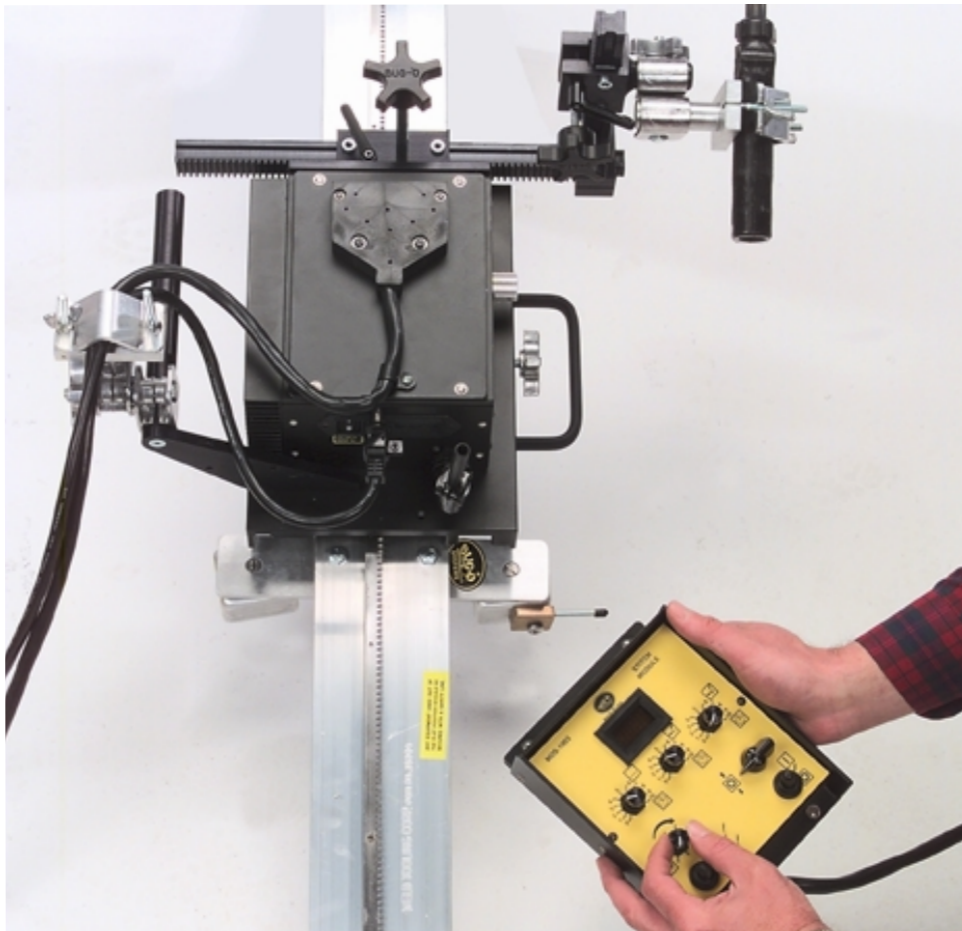

Remote Control Cable

Installs between the Master Drive Unit and the Control Module, allowing the operator to perform work in confined areas where it would be difficult to reach the controls. Two sizes are available as shown below.

Order reference: **MDS-1020** 10 Ft (3 m)
MDS-1020-25 25 Ft (7.6 m)

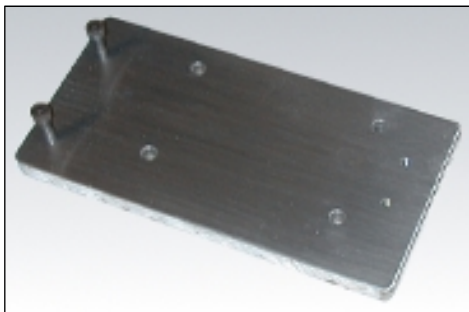

Extended Mounting Plate

Mounts to front of carriage for use with dual cutting or welding groups, heavy duty racking, etc.

Order reference: **MDS-1045**



Spacer w/Screws

Provides height required to position racking group for plasma cutting applications.

Order reference: **PAN-1001**



Quick Action Manifold

Allows quick ON/OFF of preset torch and eliminates hose strain.

Order reference: **MDS-3025** 2-Hose
MDS-9898 3-Hose

Hose Assemblies: **CIR-1010-3** 2-Hose
MUG-1119-32 3-Hose



Handle with Cable Anchor

Keeps welding cables and contact wires away from the work surface, eliminating drag.

Order reference: **MPD-1035**